



# Wenac Australia Pty Ltd

## PRODUCT APPRAISAL REPORT 1919 Issue 4

Flange Gaskets PN16 EPDM

### WSA 109-2011 Industry Standard for Flange Gaskets and O-rings

Issue 1 Published: 5 June 2020

Issue 2 Published: 16 July 2020

Issue 3 Published: 9 May 2022

Issue 4 Published: 25 June 2024

## Document History

The following information indicates the changes made to this document.

Date	Version
22 May 2020	Issue 1 Client Review
22 May 2020	Issue 1 Peer Review
5 June 2020	Publication
16 July 2020	Issue 2 Client Review
16 July 2020	Issue 2 Publication
9 May 2022	Issue 3 Client Review
9 May 2022	Issue 3 Publication
24 June 2024	Issue 3 Client Review
25 June 2024	Issue 3 Publication

## Peer Reviewers

Name/Title	Organisation	Date
Product Appraisal Technical Advisory Group	WSAA	5 June 2020
WSAA Expert Panel	WSAA	5 June 2020
Peter Pittard, WSAA Consultant	WSAA	21 May 2020
Carl Radford, Product Appraisal Manager	WSAA	5 June 2020
Peter Pittard, WSAA Consultant	WSAA	15 July 2020
Carl Radford, Product Appraisal Manager	WSAA	16 July 2020
Peter Pittard, WSAA Consultant	WSAA	9 May 2022
Carl Radford, Product Appraisal Manager	WSAA	9 May 2022
Peter Pittard, WSAA Consultant	WSAA	25 June 2024
Carl Radford, Product Appraisal Manager	WSAA	25 June 2024

## Overview of WSAA

The Water Services Association of Australia (WSAA) is the peak industry body representing the urban water industry. Our members provide water and sewerage services to over 20 million customers in Australia and New Zealand and many of Australia's largest industrial and commercial enterprises.

Based around our vision of 'customer driven, enriching life', WSAA facilitates collaboration, knowledge sharing, networking and cooperation within the urban water industry. We are proud of the collegiate attitude of our members which has led to industry-wide approaches to national water issues.

WSAA can demonstrate success in the standardisation of industry performance monitoring and benchmarking, as well as many research outcomes of national significance. The WSAA Executive retains strong links with policy makers and legislative bodies and their influencers, to monitor emerging issues of importance to the urban water industry.

WSAA was formed in 1995 as a non-profit organisation to foster the exchange of information between industry, government and the community, and to promote sustainable water resource management.

The urban water industry is committed to anchoring its services to customers' values, and to enrich communities where water services have broad economic, environmental and social values. In line with this our main activities focus on four areas:

1. influencing national and state policies on the provision of urban water services and sustainable water resource management
2. promoting debate on environmentally sustainable development and management of water resources and the community health requirements of public water supplies
3. improving industry performance and establishing benchmarks and industry leading practices for water service processes; and
4. fostering the exchange of information on education, training, research, water and wastewater management and treatment and other matters of common interest.

## Copyright

This document is copyrighted. Apart from any use as permitted under the Copyright Act 1968, no part of this document may be reproduced or transmitted in any form or by any means, electronically or mechanical, for any purpose, without the express written permission of Water Services Association of Australia Limited.

© Copyright 2024 by WATER SERVICES ASSOCIATION of Australia Limited **All rights reserved.**

## CONTENTS

1 EXECUTIVE SUMMARY .....	5
1.1 Recommendations .....	5
2 THE APPLICANT.....	5
2.1 The Supplier.....	5
2.2 The Manufacturer.....	5
3 THE PRODUCT .....	5
4 SCOPE OF THE APPRAISAL.....	6
5 APPRAISAL CRITERIA.....	6
5.1 Quality Assurance Requirements .....	6
5.2 Performance Requirements .....	7
6 COMPLIANCE WITH APPRAISAL CRITERIA.....	7
6.1 Compliance with Quality Assurance Requirements .....	7
6.2 Compliance with Performance Requirements.....	7
6.2.1 Material properties.....	7
6.2.2 Dimensions.....	7
6.2.3 Contact with drinking water .....	8
7 FITTING INSTRUCTIONS, TRAINING AND INSTALLATION .....	8
8 PRODUCT MARKING .....	8
9 PACKAGING AND TRANSPORTATION.....	8
10 PRODUCT WARRANTY .....	8
11 WATER AGENCY EXPERIENCE WITH THE PRODUCT OR FIELD-TESTING REPORT.....	8
12 OUTCOMES OF EXPERT PANEL PRODUCT REVIEW.....	8
13 FUTURE WORKS.....	8
14 DISCLAIMER.....	8
14.1 Issue of Report.....	9
14.2 Limits on Reliance on Information and Recommendations.....	9
14.2.1 Disclaimer of liability.....	9
14.2.3 Need for independent assessment.....	9
14.3 No Updating .....	10
14.4 No Warranty.....	10
APPENDIX A – PRODUCT LITERATURE .....	11
APPENDIX B – QUALITY CERTIFICATIONS.....	12
APPENDIX C – SUPPLIER CONTACTS .....	15

## 1 EXECUTIVE SUMMARY

Wenac Australia Pty Ltd is a privately-owned company, established in 2018 to provide pipeline accessories for the water and civil installation industries.

Thai Duong Joint Stock Company, located in Binh Duong Province Vietnam, manufactures the moulded EPDM flange gaskets on behalf of Wenac.

This appraisal is for DN 80 to DN 750 PN16 rated, 3mm thick, solid EPDM full face flange gaskets for water supply and sewerage applications. The gaskets are suitable for jointing PN14 or PN16 flanges complying with AS/NZS 4087 *Metallic flanges for waterworks purposes*, subject to any limitations nominated in Appendix C of that Standard.

This Issue 4 is to add additional sizes to the Scope of this Appraisal.

Thai Duong JSC holds an ISO 9001:2015 Quality Management System Licence.

This Appraisal has determined that Wenac EPDM PN16 flange gaskets, as detailed in this report, meet the requirements of WSA PS 312 *Flange gaskets and O-rings* and are considered as 'fit-for-purpose'.

### 1.1 Recommendations

It is recommended that WSAA members, subject to any specific requirements of the member, accept or authorise Wenac EPDM PN16 flange gaskets for ductile iron and grey cast iron flanges as detailed in this report, for use in water supply and sewerage applications subject to any limitations contained within WSA 109 and AS/NZS 4087.

## 2 THE APPLICANT

The Applicant is Wenac Australia Pty Ltd.

### 2.1 The Supplier

Wenac Australia Pty Ltd is a privately-owned company, established in 2018, to provide pipeline accessories for the water and civil installation industries.

The owner, Jianwen Wang, has a wide experience in various industries within Australia including automotive, construction and HVAC. For seven years prior to the establishment of Wenac, Jianwen has worked at a management level with responsibilities including product development within the water, plumbing and civil construction industries.

### 2.2 The Manufacturer

Thai Duong Joint Stock Company is located in Binh Duong Province Vietnam.

Thai Duong is a specialist rubber component manufacturer servicing the local market and exporting to USA, Europe and Australia. It is a major supplier to Hultec Australia Pty Ltd for its well-known range of pipe seals.

## 3 THE PRODUCT

This appraisal is for DN 80 to DN 750 PN16 rated, 3mm thick, solid EPDM moulded full face flange gaskets for water supply and sewerage applications. The gaskets are suitable for jointing PN14 or PN16 flanges complying with AS/NZS 4087 *Metallic flanges for waterworks purposes*

Dimensions of the full-face gaskets are detailed in Table 1 and comply with WSA 109. Wenac has advised that additional sizes will be added to the range on a continual basis.

**TABLE 1****FLANGE GASKET DIMENSIONS FOR PN16 FLANGES**

DN	Full Face Gaskets				
	Outside Diameter mm ±5	Inside Diameter mm ±1	Pitch Circle Diameter mm ±1.5	Bolt Hole Diameter mm +2, -0.5	Number of Holes
80	185	82	146	18	4
100	215	108	178	18	4
150	280	161	235	18	8
200	335	216	292	18	8
225	370	241	324	18	8
250	405	268	356	22	8
300	455	325	406	22	12
375	550	406	495	26	12
450	640	485	584	26	12
600	825	641	756	30	16
750	995	796	927	33	20

AS/NZS 4087 Appendix C provides jointing guidelines for flanged joint assemblies and also details flanges that are compatible with PN 16 elastomeric gaskets. See Table 2.

**TABLE 2****FLANGES COMPATIBLE WITH FULL FACE EPDM GASKETS**

Flange material	Flange face type	PN	DN
Copper Alloy	Flat	14	Up to DN 150
Grey Cast Iron	Flat	14	Up to DN 500
Ductile Cast Iron	Raised	16	Up to DN 750
Steel	Flat	16	Up to DN 300
Steel	Raised	16	Up to DN 600

Whilst the gasket material and mating dimensions of the standard full-face gaskets are suitable for jointing AS/NZS 4087 PN14 copper alloy and PN16 steel flanges, the inside diameter of the mating flanges should be determined to ensure the gasket does not protrude into the bore of the components. WSA 109 provides recommended gasket dimensions for various steel flanges.

**4 SCOPE OF THE APPRAISAL**

This scope of this appraisal includes DN 80, DN 100, DN 150, DN 225, DN 250, DN 300, DN 375, DN 450, DN 600 and DN 750 PN16 rated 3mm thick solid moulded EPDM full face flange gaskets suitable for water supply and sewerage applications.

**5 APPRAISAL CRITERIA****5.1 Quality Assurance Requirements**

The WSAA Product Appraisal Technical Advisory Group accepts flange gaskets manufactured in compliance with WSA 109:2021 *Industry standard for flange gaskets and O-rings* and duly certified by means of an ISO Type 3 product certification scheme

undertaken by a JAS-ANZ accredited Conformity Assessment Body (CAB) or by an international accreditation system recognised by JAS-ANZ. In this case the submission of appropriate type test requirements to demonstrate compliance with WSA 109 has been deemed acceptable.

The manufacturer is generally expected to have a production management and control system that has been duly accredited in accordance with ISO 9001 as a prerequisite to undergoing a product certification audit.

## **5.2 Performance Requirements**

Wenac flange gaskets have been appraised for compliance with WSA 109:2021 *Industry standard for flange gaskets and O-rings*.

Appraisal criteria are also determined by the WSAA Product Appraisal Technical Advisory Group and regularly reviewed to ensure that the criteria reflect the requirements of WSAA members.

The following Product Specification is also relevant to this application:

WSA PS-312 *Flange gaskets and O-rings*

A copy of the Product Specification is available at the following link:

<https://www.wsaa.asn.au/shop/product/60961>

## **6 COMPLIANCE WITH APPRAISAL CRITERIA**

### **6.1 Compliance with Quality Assurance Requirements**

Wenac has submitted the following quality certificates:

- ISO 9001:2015 Certificate of Registration No. 01 100 106571 issued to Thai Duong Joint Stock Company by TUV Rheinland.
- AS 1646:2007 ApprovalMark ISO Type 5 Product Certification Licence No. AMI 74510 issued to Thai Duong Joint Stock Company by ApprovalMark International.

The flange gaskets do not have ISO Type 3 product certification however relevant test reports have been submitted to demonstrate compliance with WSA 109:2021 *Industry Standard for flange gaskets and O-rings*.

Copies of the Quality Assurance certificates have been included in Appendix B and are also available from WSAA.

### **6.2 Compliance with Performance Requirements**

#### **6.2.1 Material properties**

Wenac has provided a copy of a test report completed by Akron Rubber Development Laboratory Inc (accredited by American Association for Laboratory Accreditation A2LA) in Ohio USA to demonstrate compliance of the EPDM material properties specified in WSA 109. The tests completed for the EPDM HT 5717 were hardness, tensile strength and elongation at break in as received condition and after accelerated ageing in air at 70°C for 7 days, compression set in air at 23°C and 70°C, stress relaxation in compression and volume change in water. The results submitted comply with the requirements of WSA 109 which requires compliance with AS 1646 and AS 681-1.

Thai Duong JSC has an AS 1646 ISO Type 5 Product Certification which includes other products manufactured from EPDM HT 5717.

#### **6.2.2 Dimensions**

The dimensions of the gaskets submitted on product drawings and detailed in Table 1 comply with WSA 109.

### **6.2.3 Contact with drinking water**

A test report completed by Eurofins ams (NATA Accreditation No 15773) for EPDM HT 5717 dated 14<sup>th</sup> August 2020 to demonstrate compliance with AS/NZS 4020 is held on file by WSAA.

## **7 FITTING INSTRUCTIONS, TRAINING AND INSTALLATION**

AS/NZS 4087 Appendix C provides guidance for the selection of correct jointing requirements for flanges, including flange face type, gasket type / thickness and minimum property class for fasteners. WSA 109 Appendix D provides informative procedures for assembling flanged joints.

## **8 PRODUCT MARKING**

Markings are moulded on tags located on the outer rim of each gasket in compliance with WSA 109 as follows:

- Manufacturers name: WENAC
- Nominal size: e.g. DN 100
- Number of the standard: WSA109
- Year of manufacture: e.g. 2020
- Type of application: WA
- Rubber type: EPDM

Example: WENAC DN100 PN16 EPDM WSA109 WA-70

## **9 PACKAGING AND TRANSPORTATION**

Gaskets are packed in quantities depending on the size and order quantity. Wenac also offers flange jointing kits that include a flange gasket complete with either Grade 316 stainless steel or galvanised steel fasteners.

## **10 PRODUCT WARRANTY**

The products are covered by the normal commercial and legal requirements of the *Competition and Consumer Act 2010 (Cth)*, which covers manufacture to the relevant standard, and details of Wenac's warranty is included in their terms and conditions of sale.

## **11 WATER AGENCY EXPERIENCE WITH THE PRODUCT OR FIELD-TESTING REPORT**

This is a mature product and nothing would be gained by a field test.

## **12 OUTCOMES OF EXPERT PANEL PRODUCT REVIEW**

No issues were raised.

## **13 FUTURE WORKS**

No future works have been identified.

## **14 DISCLAIMER**

This Product Appraisal Report (Report) is issued by the Water Services Association of Australia Limited on the understanding that:

This Report applies to the product(s) as submitted. Any changes to the product(s) either minor or major shall void this Report.

To maintain the recommendations of this Report any such changes shall be detailed and notified to the Product Appraisal Manager for consideration and review of the Report and



appropriate action. Appraisals and their recommendations will be the subject of continuous review dependent upon the satisfactory performance of products.

WSAA reserves the right to undertake random audits of product manufacture and installation. Where products fail to maintain appraised performance requirements the appraisal and its recommendations may be modified and reissued. Appraisal reports will be reviewed and reissued at regular intervals not exceeding five (5) years.

The following information explains a number of very important limits on your ability to rely on the information in this Report. Please read it carefully and take it into account when considering the contents of this Report.

Any enquiries regarding this report should be directed to the Program Manager, Carl Radford, email [carl.radford@wsaa.asn.au](mailto:carl.radford@wsaa.asn.au).

#### **14.1 Issue of Report**

This Report has been published and/or prepared by the Water Services Association of Australia Limited and nominated Project Manager and peer group of technical specialists (the Publishers).

The Report has been prepared for use within Australia only by technical specialists that have expertise in the function of products such as those appraised in the Report (the Recipients).

By accepting this Report, the Recipient acknowledges and represents to the Publisher(s) and each person involved in the preparation of the Report that the Recipient has understood and accepted the terms of this Disclaimer.

#### **14.2 Limits on Reliance on Information and Recommendations**

##### **14.2.1 Disclaimer of liability**

Neither the Publisher(s) nor any person involved in the preparation of the Report accept(s) any liability for any loss or damage suffered by any person however caused (including negligence or the omission by any person to do anything) relating in any way to the Report or the product appraisal criteria underlying it. This includes (without limitation) any liability for any recommendation or information in the Report or any errors or omissions.

##### **14.2.2 Intellectual Property and other rights**

The Water Services Association of Australia Limited does not undertake any assessment of whether the importation, manufacture, sale or use of the Product the subject of this Report infringes the intellectual property rights or proprietary rights of any person. Recipients of the report should undertake their own assessment of whether (as relevant) the importation, manufacture, sale or use of the relevant Products infringe the intellectual property rights or other proprietary rights of any person. If the Product infringes intellectual property rights or other proprietary rights there is potential for the supply of the Products to be interrupted.

From time to time the Water Services Association of Australia Limited and the other Publishers may receive notice of allegations that the importation, manufacture, sale or use of the Product infringes intellectual property rights or other proprietary rights. The Water Services Association of Australia Limited's policy is to not refer to such allegations in its reports or take any other steps to put Recipients on notice of such allegations, unless and until it is aware that the allegations have been admitted or proved in Court. As such, Recipients acknowledge, agree and accept that the Water Services Association of Australia Limited may have information in its possession about intellectual property rights infringement allegations or other infringement allegations in relation to the Product which are not referred to or disclosed in this Report and which are not otherwise communicated to Recipients.

##### **14.2.3 Need for independent assessment**

The information and any recommendation contained (expressly or by implication) in this Report are provided in good faith (and subject to the limitations noted in this Report).

However, you should treat the information as indicative only. You should not rely on that information or any such recommendation except to the extent that you reach an agreement to the contrary with the Publisher(s).

This Report does not contain all information that a person might require for the purposes of assessing any product discussed or appraised within it. The product appraisal criteria used in preparing this Report may not address all relevant aspects of the Product.

Recipients should seek independent evidence of any matter which is material to their decisions in connection with an assessment of the Product and consult their own advisers for any technical information required. Any decision to use the Product should take into account the reliability of that independent evidence obtained by the Recipient regarding the Product.

Recipients should also independently verify and assess the appropriateness of any recommendation in the Report, especially given that any recommendation will not take into account a Recipient's particular needs or circumstances.

WSAA has not evaluated the extent of the product liability and professional indemnity insurance that the provider of the product maintains. Recipients should ensure that they evaluate the allocation of liability for product defects and any professional advice obtained in relation to the product or its specification including the requirements for product liability and professional indemnity insurance.

### **14.3 No Updating**

Neither the Publisher(s) nor any person involved in the preparation of this Report [has] [have] any obligation to notify you of any change in the information contained in this Report or of any new information concerning the Publisher(s) or the Product or any other matter.

### **14.4 No Warranty**

The Publisher(s) do[es] not, in any way, warrant that steps have been taken to verify or audit the accuracy or completeness of the information in this Report, or the accuracy, completeness or reasonableness of any recommendation in this Report.

**APPENDIX A – PRODUCT LITERATURE**



## EPDM Flange Gasket

**Size available:**  
 DN80 – DN750  
 (size above DN300 made to order)

**Material:** AS1646/EN681.1  
 EPDM Black  
 Hardness 70 IRHD

### System Applications

- Flange sealing rubber gaskets compatible to AS/NZS 4087 and AS2129 Table D and E (optional)
- Pressure rating up to PN16

### Compliance Standards and Approvals

- Comply with WSA109 specification
- EPDM comply with AS1646
- certified to AS/NZS 4020

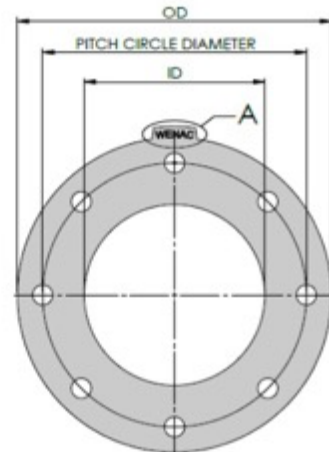

Sizes above DN300 are made to order

### More Enquiries

**Wenac Australia P/L**

**7 / 5 Turbo Drive,  
 Bayswater North**

**Ph: 0452 118 008**

**Email:**

[jw@wenac.com.au](mailto:jw@wenac.com.au)

**Website:**

[www.wenac.com.au](http://www.wenac.com.au)

DN	Part No	OD	ID	PCD	Hole	Bolt Size
80	GSK080	185	82	146	4 x 18	M16
100	GSK100	215	108	178	4 x 18	M16
150	GSK150	280	161	235	8 x 18	M16
200	GSK200	335	216	292	8 x 18	M16
225	GSK225	370	241	324	8 x 18	M16
250	GSK250	405	268	356	8 x 22	M20
300	GSK300	455	325	406	12 x 22	M20

## APPENDIX B – QUALITY CERTIFICATIONS

Copies of the following Quality Certification Certificates are available from WSAA.

**TABLE B1  
THAI DUONG JSC – MANAGEMENT SYSTEMS**

Lot A-6B-CN. My Phuoc 3 Industrial Park Ben Cat Town Bin Duong Province Vietnam	
Quality Systems Standard	ISO9001:2015
Certification Licence No.	01 100 106571/01
Certifying Agency	TUV Rheinland
Current Date of Certification	4 September 2021
Expiry Date of Certification	3 September 2024

**TABLE B2 THAI DUONG JSC – PRODUCT CERTIFICATION**

Lot A-6B-CN. My Phuoc 3 Industrial Park Ben Cat Town Bin Duong Province Vietnam	
Product Standard/Spec.	AS 1646:2007
Certificate No.	AMI 74510
Issuing Certification Body	Approval Mark International
First Date of Certification	10 February 2013
Current Date of Certification	10 February 2023
Expiry Date of Certification	10 February 2028

# Certificate

Standard **ISO 9001:2015**

Certificate Registr. No. **01 100 106571**

Certificate Holder: **THAI DUONG JOINT STOCK COMPANY**  
Lot A-6B-CN, My Phuoc 3 Industrial Park,  
Chanh Phu Hoa Ward, Ben Cat Town,  
Binh Duong Province, Vietnam.

Scope: **Manufacture & supply of technical rubber products and plastic products.**

Proof has been furnished by means of an audit that the requirements of ISO 9001:2015 are met.

Validity: **The certificate is valid from 04.09.2021 until 03.09.2024 .  
First certification 2010**

12.08.2021

  
TÜV Rheinland Cert GmbH  
Am Grauen Stein · 51105 Köln

www.tuv.com



ISO TYPE 5

# CERTIFICATE OF CONFORMITY



*ApprovalMark International* hereby grants:

## THAI DUONG JOINT STOCK COMPANY - HULTEC ASIA PACIFIC PTY LTD

Lot A 6B-CN, My Phuoc 3 Industrial Park  
Ben Cat District, Binh Duong Province  
VIETNAM

### ISO Type 5 Certificate of Conformity

Evaluated to:

### AS 1646:2007 – Elastomeric seals for waterworks purposes

The ISO Type 5 License shall comply with all the terms and conditions as stipulated by the governance of the operating rules of the ISO Type 5 Scheme and shall comply with the standard requirements at all times including when the standard is amended. The ISO Type 5 License only covers the product which is identified in the attached product schedule.

Certificate No. AMI 74510

Issued: 10<sup>th</sup> February 2023

Original Issue: 10<sup>th</sup> February 2013

Expires: 10<sup>th</sup> February 2028

**John PRASAD**

Director

ApprovalMark International Pty Ltd  
20/33 Holbeche Road, Arndell Park 2148, Australia  
[www.approvalmark.com](http://www.approvalmark.com)



Registered by: ApprovalMark International Pty Ltd (ABN 69 143 259 974) Unit 20, 33 Holbeche Road, Arndell Park NSW 2148 Australia. The assessment was carried with appropriate skill and assessment by ApprovalMark International Pty Ltd; however it will only accept its responsibility for proven negligence. The certificate remains the property of ApprovalMark International Pty Ltd.

ApprovalMark™

## **APPENDIX C – SUPPLIER CONTACTS**

### **Wenac Australia Pty Ltd**

7/5 Turbo Drive

Bayswater North VIC

Tel: 0452 118 008

Email: [jw@wenac.com.au](mailto:jw@wenac.com.au)

Web: [www.wenac.com.au](http://www.wenac.com.au)



**Melbourne Office**

Wurundjeri Country  
Level 8, Suite 8.02  
401 Docklands Drive  
Docklands VIC 3008

**Sydney Office**

Gadigal Country  
Level 6 75 Elizabeth Street  
Sydney NSW 2000  
GPO Box 915  
Sydney NSW 2001

P +61 (0) 3 8605 7600  
email: [info@wsaa.asn.au](mailto:info@wsaa.asn.au)

[www.wsaa.asn.au](http://www.wsaa.asn.au)